

"OMNIFET": FULLY AUTOPROTECTED POWER MOSFET

TYPE	V _{clamp}	R _{DS(on)}	I _{lim}
VNP10N06	60 V	0.3 Ω	10 A

- LINEAR CURRENT LIMITATION
- THERMAL SHUT DOWN
- SHORT CIRCUIT PROTECTION
- INTEGRATED CLAMP
- LOW CURRENT DRAWN FROM INPUT PIN
- LOGIC LEVEL INPUT THRESHOLD
- ESD PROTECTION
- SCHMITT TRIGGER ON INPUT
- HIGH NOISE IMMUNITY
- STANDARD TO-220 PACKAGE

DESCRIPTION

The VNP10N06 is a monolithic device made using SGS-THOMSON Vertical Intelligent Power M0 Technology, intended for replacement of standard power MOSFETS in DC to 50 KHz applications. Built-in thermal shut-down, linear current limitation and overvoltage clamp protect the chip in harsh environments.

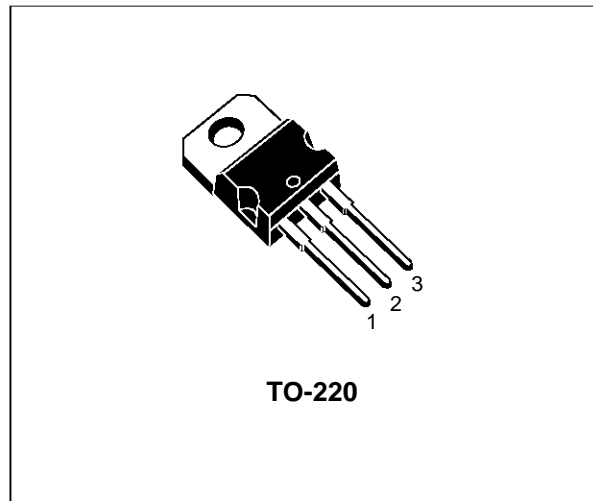

BLOCK DIAGRAM

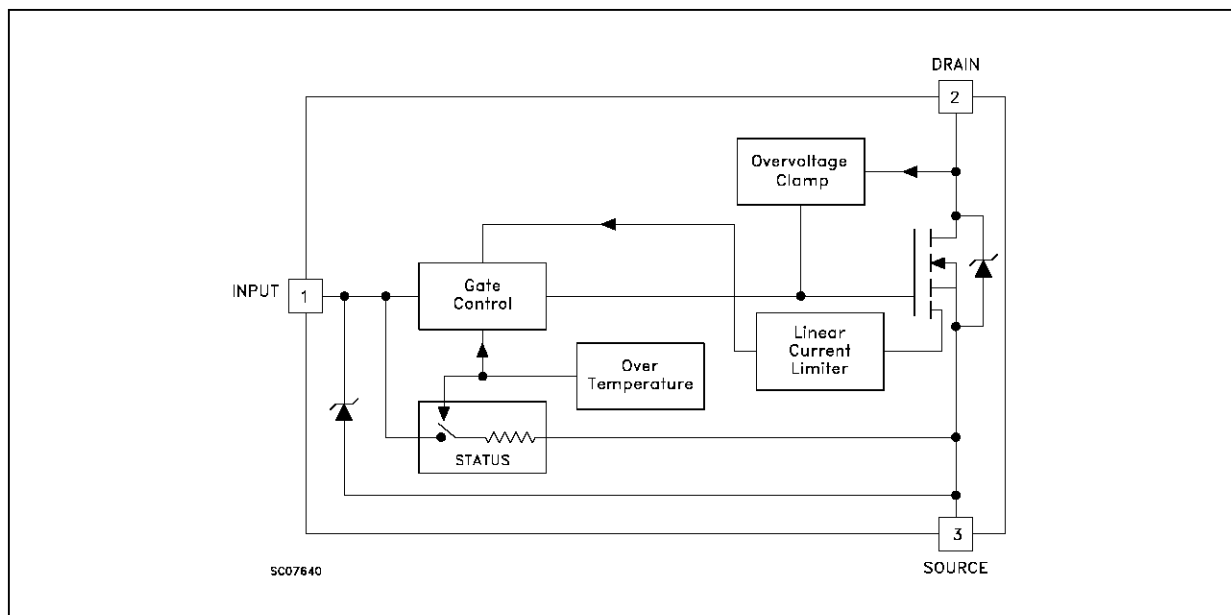

ABSOLUTE MAXIMUM RATING

Symbol	Parameter	Value	Unit
V _{DS}	Drain-source Voltage (V _{in} = 0)	Internally Clamped	V
V _{in}	Input Voltage	Internally Clamped	V
I _{in}	Input Current	± 20	mA
I _D	Drain Current	Internally Limited	A
I _R	Reverse DC Output Current	-15	A
V _{esd}	Electrostatic Discharge (C= 100 pF, R=1.5 KΩ)	4000	V
P _{tot}	Total Dissipation at T _c = 25 °C	42	W
T _j	Operating Junction Temperature	Internally Limited	°C
T _c	Case Operating Temperature	Internally Limited	°C
T _{stg}	Storage Temperature	-55 to 150	°C

THERMAL DATA

R _{thj-case}	Thermal Resistance Junction-case	Max	3	°C/W
R _{thj-amb}	Thermal Resistance Junction-ambient	Max	62.5	°C/W

ELECTRICAL CHARACTERISTICS (T_{case} = 25 °C unless otherwise specified)

OFF

Symbol	Parameter	Test Conditions	Min.	Typ.	Max.	Unit
V _{CLAMP}	Drain-source Clamp Voltage	I _D = 200 mA V _{in} = 0	50	60	70	V
V _{IL}	Input Low Level Voltage	I _D = 100 μA V _{DS} = 16 V			1.5	V
V _{IH}	Input High Level Voltage	R _L = 27 Ω V _{DD} = 16 V V _{DS} = 0.5 V	3.2			V
V _{INCL}	Input-Source Reverse Clamp Voltage	I _{in} = -1 mA I _{in} = 1 mA	-1 8		-0.3 11	V V
I _{DSS}	Zero Input Voltage Drain Current (V _{in} = 0)	V _{DS} = 50 V V _{in} = V _{IL} V _{DS} < 35 V V _{in} = V _{IL}			250 100	μA μA
I _{ISS}	Supply Current from Input Pin	V _{DS} = 0 V V _{in} = 5 V		150	300	μA

ON (*)

Symbol	Parameter	Test Conditions	Min.	Typ.	Max.	Unit
R _{DS(on)}	Static Drain-source On Resistance	V _{in} = 7 V I _D = 1 A		0.15	0.3	Ω

DYNAMIC

Symbol	Parameter	Test Conditions	Min.	Typ.	Max.	Unit
C _{oss}	Output Capacitance	V _{DS} = 13 V f = 1 MHz V _{in} = 0		350	500	pF

ELECTRICAL CHARACTERISTICS (continued)**SWITCHING (**)**

Symbol	Parameter	Test Conditions	Min.	Typ.	Max.	Unit
$t_{d(on)}$	Turn-on Delay Time	$V_{DD} = 16\text{ V}$ $I_d = 1\text{ A}$		1100	1600	ns
t_r	Rise Time	$V_{gen} = 7\text{ V}$ $R_{gen} = 10\ \Omega$		550	900	ns
$t_{d(off)}$	Turn-off Delay Time	(see figure 3)		200	400	ns
t_f	Fall Time			100	200	ns
$t_{d(on)}$	Turn-on Delay Time	$V_{DD} = 16\text{ V}$ $I_d = 1\text{ A}$		1.2	1.8	μs
t_r	Rise Time	$V_{gen} = 7\text{ V}$ $R_{gen} = 1000\ \Omega$		1	1.5	μs
$t_{d(off)}$	Turn-off Delay Time	(see figure 3)		1.6	2.3	μs
t_f	Fall Time			1.2	1.8	μs
$(di/dt)_{on}$	Turn-on Current Slope	$V_{DD} = 16\text{ V}$ $I_D = 1\text{ A}$ $V_{in} = 7\text{ V}$ $R_{gen} = 10\ \Omega$		1.5		A/ μs
Q_i	Total Input Charge	$V_{DD} = 12\text{ V}$ $I_D = 1\text{ A}$ $V_{in} = 7\text{ V}$		13		nC

SOURCE DRAIN DIODE

Symbol	Parameter	Test Conditions	Min.	Typ.	Max.	Unit
$V_{SD} (*)$	Forward On Voltage	$I_{SD} = 1\text{ A}$ $V_{in} = V_{IL}$		0.8	1.6	V
$t_{rr} (**)$	Reverse Recovery Time	$I_{SD} = 1\text{ A}$ $di/dt = 100\text{ A}/\mu\text{s}$ $V_{DD} = 30\text{ V}$ $T_j = 25\text{ }^\circ\text{C}$		125		ns
$Q_{rr} (**)$	Reverse Recovery Charge	(see test circuit, figure 5)		0.22		μC
$I_{RRM} (**)$	Reverse Recovery Current			3.5		A

PROTECTION

Symbol	Parameter	Test Conditions	Min.	Typ.	Max.	Unit
I_{lim}	Drain Current Limit	$V_{in} = 7\text{ V}$ $V_{DS} = 13\text{ V}$	6	10	15	A
$t_{dim} (**)$	Step Response Current Limit	$V_{in} = 7\text{ V}$ V_{DS} step from 0 to 13 V		12	20	μs
$T_{jsh} (**)$	Overtemperature Shutdown		150			$^\circ\text{C}$
$T_{jrs} (**)$	Overtemperature Reset		135			$^\circ\text{C}$
$E_{as} (**)$	Single Pulse Avalanche Energy	starting $T_j = 25\text{ }^\circ\text{C}$ $V_{DD} = 24\text{ V}$ $V_{in} = 7\text{ V}$ $R_{gen} = 1\text{ K}\Omega$ $L = 10\text{ mH}$	250			mJ

(*) Pulsed: Pulse duration = 300 μs , duty cycle 1.5 %

(**) Parameters guaranteed by design/characterization

PROTECTION FEATURES

During Normal Operation, the INPUT pin is electrically connected to the gate of the internal power MOSFET through a low impedance path as soon as $V_{IN} > V_{IH}$.

The device then behaves like a standard power MOSFET and can be used as a switch from DC to 50KHz. The only difference from the user's standpoint is that a small DC current (typically 150 μ A) flows into the INPUT pin in order to supply the internal circuitry.

During turn-off of an unclamped inductive load the output voltage is clamped to a safe level by an integrated Zener clamp between DRAIN pin and the gate of the internal Power MOSFET.

In this condition, the Power MOSFET gate is set

to a voltage high enough to sustain the inductive load current even if the INPUT pin is driven to 0V. The device integrates an active current limiter circuit which limits the drain current I_D to I_{lim} whatever the INPUT pin Voltage.

When the current limiter is active, the device operates in the linear region, so power dissipation may exceed the heatsinking capability. Both case and junction temperatures increase, and if this phase lasts long enough, junction temperature may reach the overtemperature threshold T_{jsh} .

If T_j reaches T_{jsh} , the device shuts down whatever the INPUT pin voltage. The device will restart automatically when T_j has cooled down to T_{jrs}

Thermal Impedance

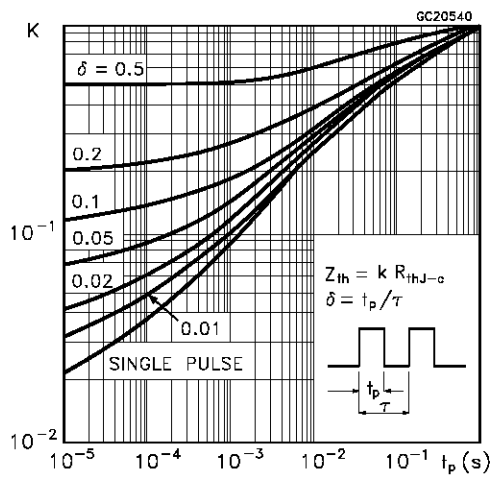

Derating Curve

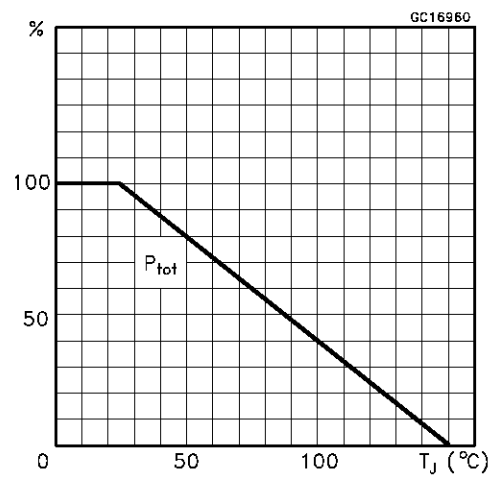

Output Characteristics

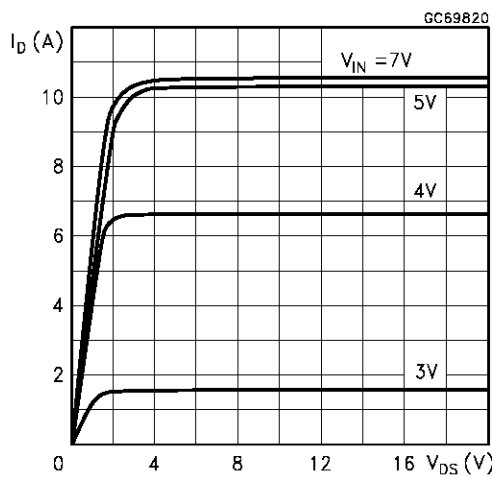

Static Drain-Source On Resistance vs Input Voltage

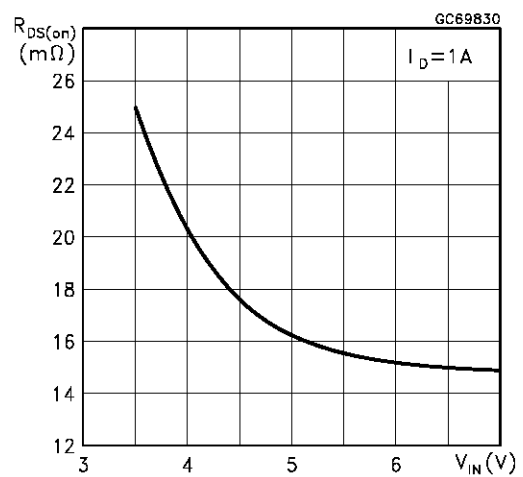

Static Drain-Source On Resistance

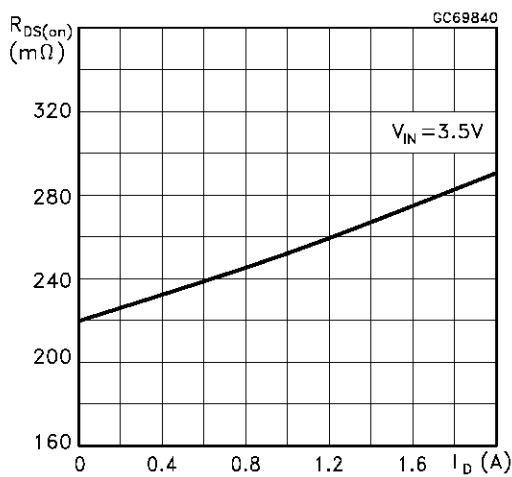

Static Drain-Source On Resistance

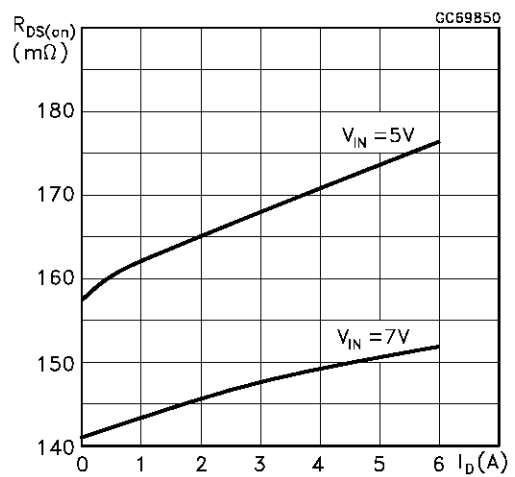

Input Charge vs Input Voltage

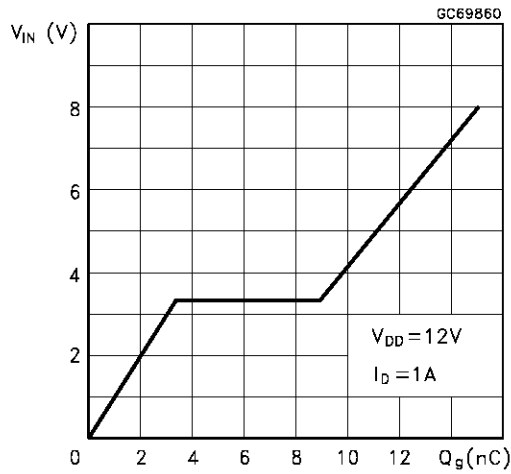

Capacitance Variations

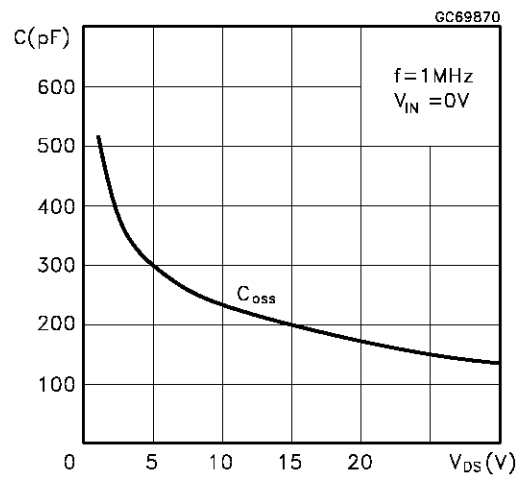

Normalized Input Threshold Voltage vs Temperature

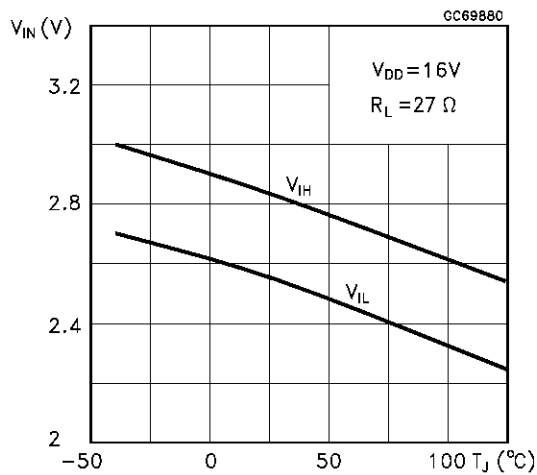

Normalized On Resistance vs Temperature

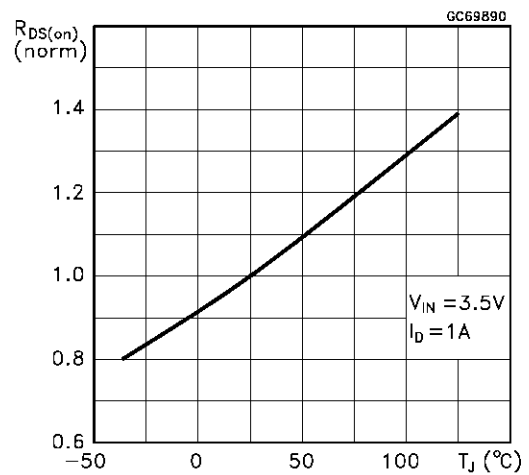

Normalized On Resistance vs Temperature

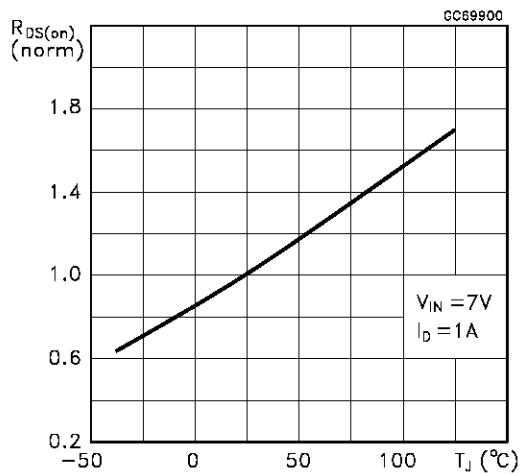

Turn-on Current Slope

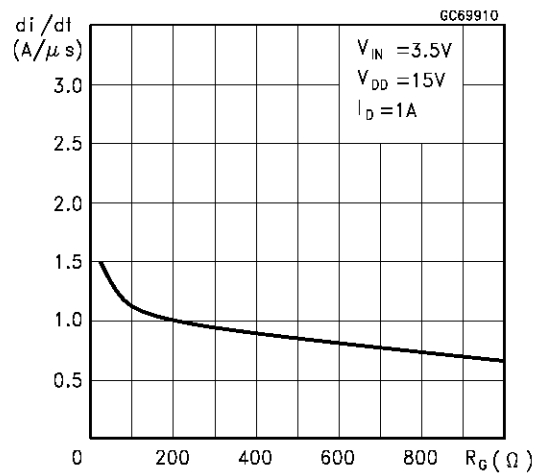

Turn-on Current Slope

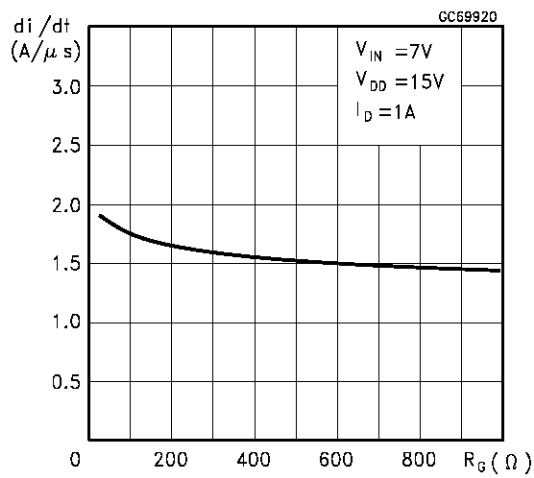

Turn-off Drain-Source Voltage Slope

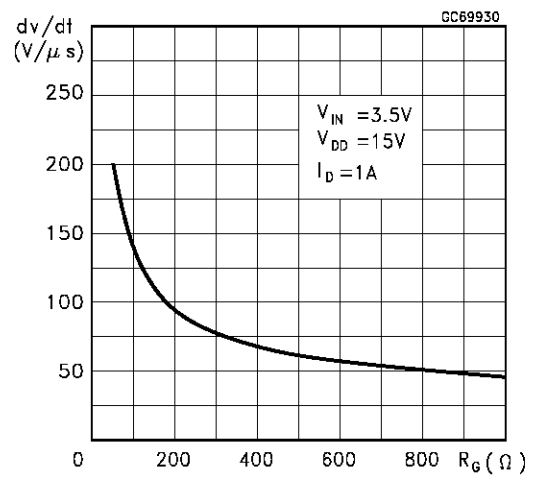

Turn-off Drain-Source Voltage Slope

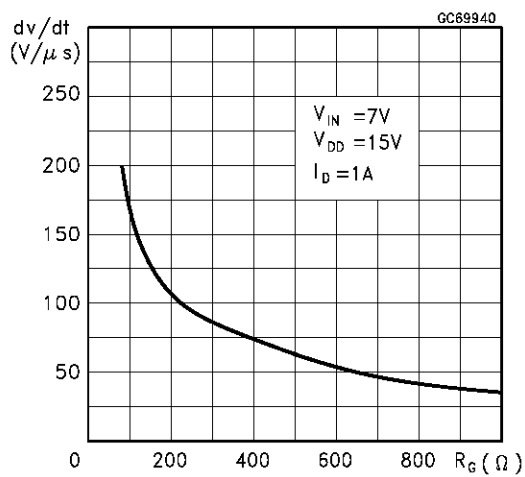

Switching Time Resistive Load

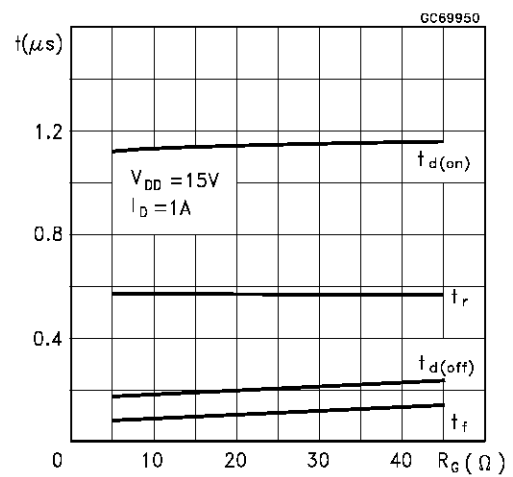

Switching Time Resistive Load

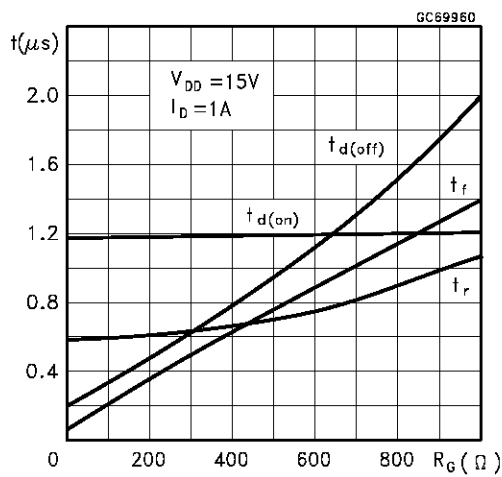

Switching Time Resistive Load

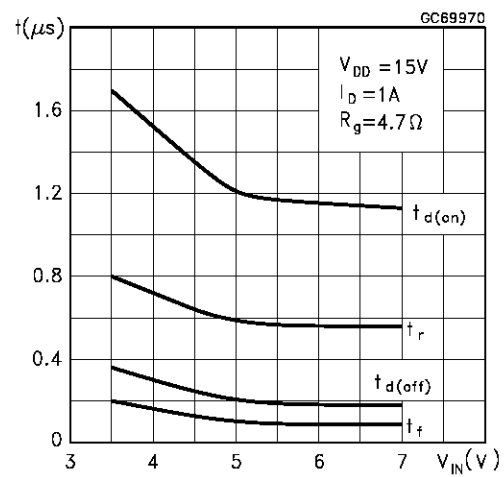

Current Limit vs Junction Temperature

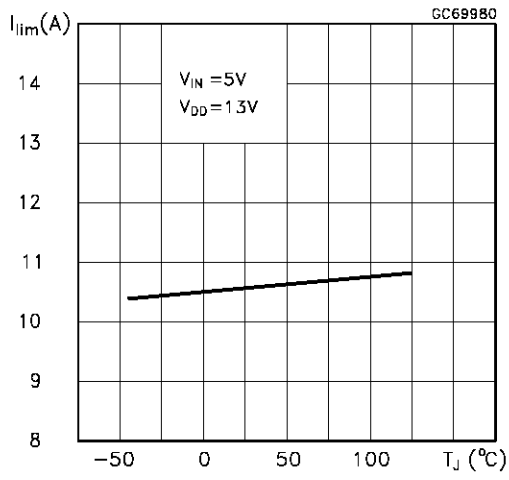

Step Response Current Limit

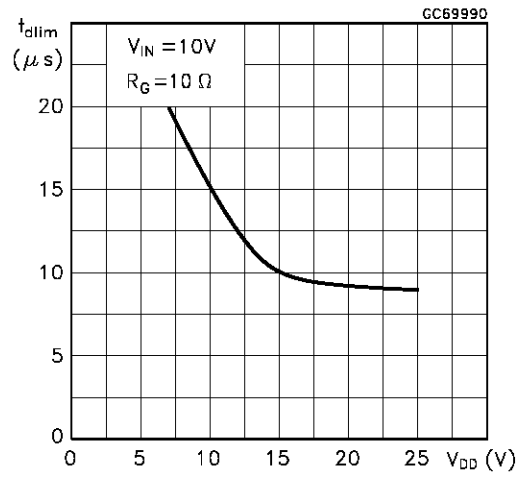

Source Drain Diode Voltage vs Junction Temperature

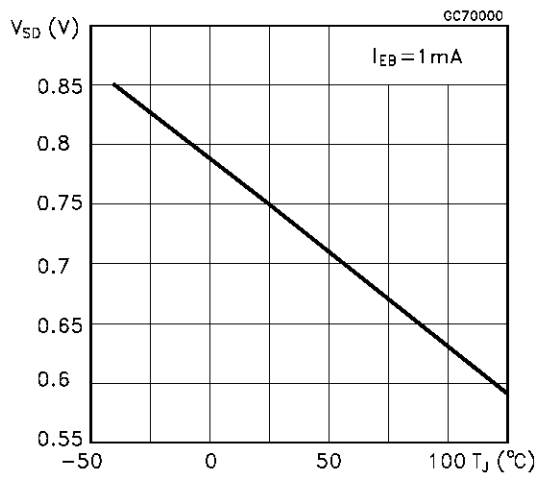

Fig. 1: Unclamped Inductive Load Test Circuits

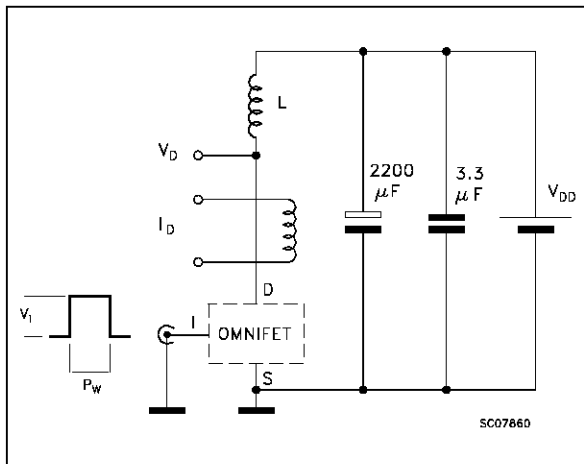

Fig. 2: Unclamped Inductive Waveforms

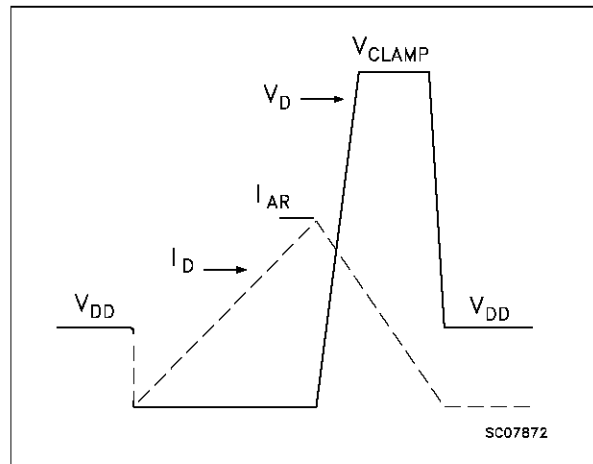

Fig. 3: Switching Times Test Circuits For Resistive Load

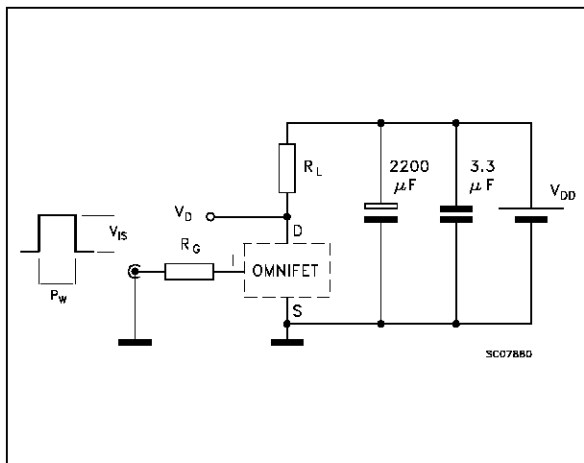

Fig. 4: Input Charge Test Circuit

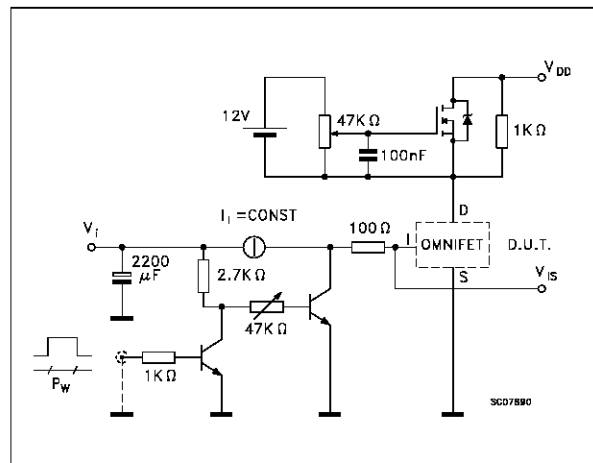

Fig. 5: Test Circuit For Inductive Load Switching And Diode Recovery Times

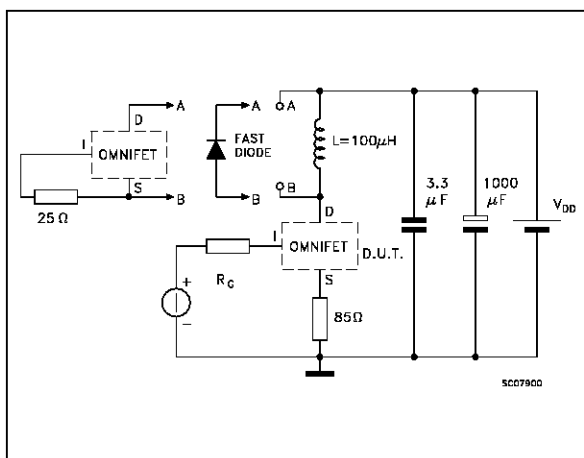
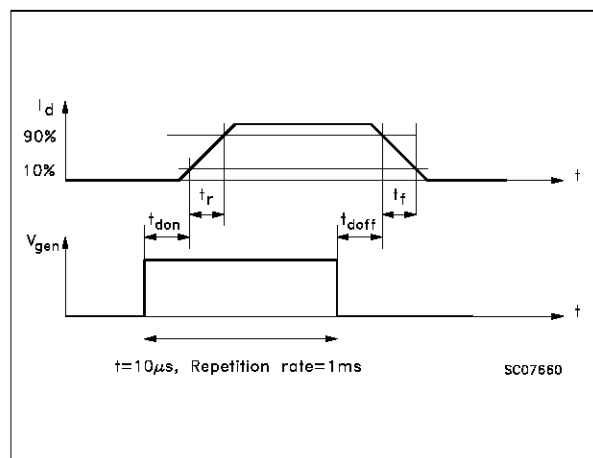
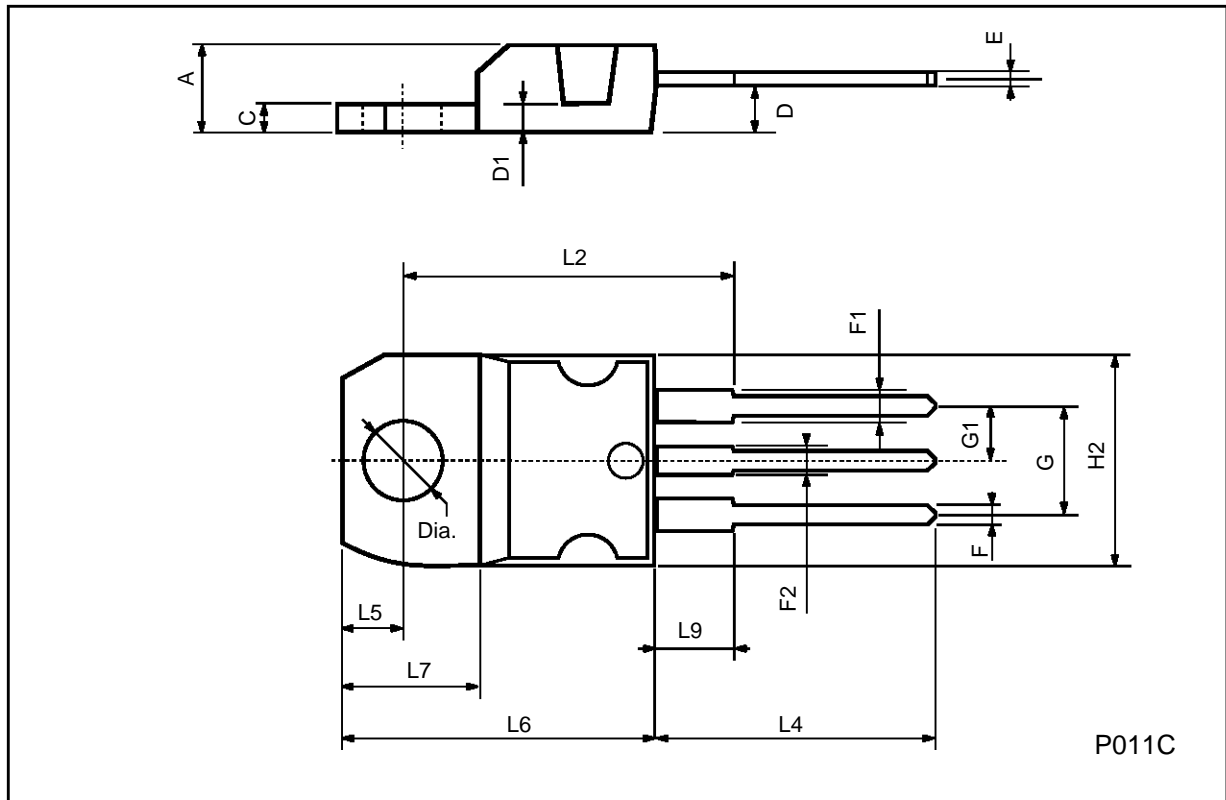

Fig. 6: Waveforms



TO-220 MECHANICAL DATA

DIM.	mm			inch		
	MIN.	TYP.	MAX.	MIN.	TYP.	MAX.
A	4.40		4.60	0.173		0.181
C	1.23		1.32	0.048		0.051
D	2.40		2.72	0.094		0.107
D1		1.27			0.050	
E	0.49		0.70	0.019		0.027
F	0.61		0.88	0.024		0.034
F1	1.14		1.70	0.044		0.067
F2	1.14		1.70	0.044		0.067
G	4.95		5.15	0.194		0.203
G1	2.4		2.7	0.094		0.106
H2	10.0		10.40	0.393		0.409
L2		16.4			0.645	
L4	13.0		14.0	0.511		0.551
L5	2.65		2.95	0.104		0.116
L6	15.25		15.75	0.600		0.620
L7	6.2		6.6	0.244		0.260
L9	3.5		3.93	0.137		0.154
DIA.	3.75		3.85	0.147		0.151



Information furnished is believed to be accurate and reliable. However, SGS-THOMSON Microelectronics assumes no responsibility for the consequences of use of such information nor for any infringement of patents or other rights of third parties which may result from its use. No license is granted by implication or otherwise under any patent or patent rights of SGS-THOMSON Microelectronics. Specifications mentioned in this publication are subject to change without notice. This publication supersedes and replaces all information previously supplied. SGS-THOMSON Microelectronics products are not authorized for use as critical components in life support devices or systems without express written approval of SGS-THOMSON Microelectronics.

© 1996 SGS-THOMSON Microelectronics - Printed in Italy - All Rights Reserved

SGS-THOMSON Microelectronics GROUP OF COMPANIES

Australia - Brazil - Canada - China - France - Germany - Hong Kong - Italy - Japan - Korea - Malaysia - Malta - Morocco - The Netherlands - Singapore - Spain - Sweden - Switzerland - Taiwan - Thailand - United Kingdom - U.S.A